



## Specifications for Rubaroc Safety Surfacing

---

### PART I – GENERAL

1.1 WORK INCLUDED: Work in this section includes furnishing all labour, materials, equipment, and services required to install all poured-in-place granular rubber surfacing. It will be completed to drawing details and specifications.

1.2 RELATED WORK SPECIFIED ELSEWHERE: Poured-in place concrete, compacted crushed stone, asphalt, interlocking brick, geotextile fabric or filter cloth, marine plywood or other approved substrate & retaining walls.

1.3 SUBMITTAL: Submit full range of sample colours and finishes available & sales literature.

1.4 DELIVERY AND STORAGE: Deliver materials in manufacturer's clearly labeled, unopened containers. Store and handle in a manner, which will prevent intrusion of foreign matter and will assure protection from weather. All resins and solvents should be stored at a temperature of not less than 0 degrees C (32 degrees F).

1.5 SCHEDULING: Co-ordinate the delivery of the materials with the scheduled time of installation to insure minimum storage time at the project site.

1.6 WARRANTY: All materials under this section shall be installed by a dealer authorized by the manufacturer and shall be guaranteed by the manufacturer against defects only as described in the manufacturer's warranty to the authorized dealer. The labour and installation warranty period for Playgrounds, Splash Pads, Waterparks, Animal-use Facilities, Golf Courses, Garages, Driveways or any other Commercial or non-residential application shall be ONE to FIVE (1 – 5) YEARS and the warranty for Residential foot-traffic-only applications shall be ONE to TEN (1 - 10) YEARS as specified and provided by the authorized dealer.

1.7 CONTRACTOR: The authorized dealer must have installed at least 25 applications of a similar size project and have a minimum of 5 years of experience in the poured-in-place rubber safety surfacing industry.

1.8 JOB CONDITIONS: The air temperature is recommended to be above 5 degrees C (41 degrees F) day and night. Any temperatures below this may affect the speed and quality of the installation.

Bounces like rubber. Wears like rock.®

[www.rubaroc.com](http://www.rubaroc.com) | 1-877-782-2762 | [info@rubaroc.com](mailto:info@rubaroc.com)



## PART II – PRODUCTS

2.1 MANUFACTURER: Recycled granular or virgin EPDM or SBR rubber granules and accessory materials such as binders and solvents shall be as produced and/or supplied by Softroc or equal as approved by the client.

### 2.2 MATERIALS:

- A. Granules – Pure vulcanized EPDM rubber chips ranging in size 1 - 4mm. EPDM rubber shall be UV stable.
- B. Binder – Resin (Chemical Family: Aromatic (Standard Resins) or Aliphatic (UV Resins) Isocyanate). Binder shall be 100% urethane and contain no TDI. Accelerators may be used with aliphatic binders. (Aliphatic binders should be considered on indoor applications where there is UV exposure or where light coloured rubber granules are used).
- C. Primer – Aromatic or Aliphatic Resin thinned with solvent.
- D. Matrix – Resin mixed with a thickening agent, used as a base coat to allow application of rubber on vertical surfaces such as stair risers and concrete pool copings.
- E. Finished Floor Properties:
  - i. Surface to withstand 600-psi tensile stress.
  - ii. Surface to be slip resistant when wet or dry.
  - iii. Surface to be fungus resistant (trace to no growth).
  - iv. Surface to have chemical resistance (treated surface immersed for 24 hours) so that there is no effect from oil, lye, hydrochloric acid, animal fat, grease, acetone, tolidine, alcohol, blood, chlorine, urine, detergents and insect spray.

FINISHES: Pool Decks, Splash pads, Patios, Walkways, Driveways, Cart paths etc.

- i. Impact absorbing, cushioned surface
- ii. Condition of the substrate must be approved by authorized Softroc representative
- iii. Logos or designs can be incorporated into the finished surface
- iv. Softroc surface to be minimum 6mm and maximum of 12mm thick
- v. Pool decks should be left for 1-2 days before general use, and splash pads should be left for 5 days before general use.

Bounces like rubber. Wears like rock.®

[www.rubaroc.com](http://www.rubaroc.com) | 1-877-782-2762 | [info@rubaroc.com](mailto:info@rubaroc.com)



FINISHES: Splash pad, Water play (two-tier system)

- i. Two-tier system over compacted "A" Gravel.
- ii. Base of Softroc full profile water play system to consist of recycled EPDM or SBR (plus optional pea- stone) mix. Rubber to be no less than 80% of mixture.
- iii. Base to be no installed to specified depth.
- iv. Base coat binder to be used in the base layer.
- v. Base coat to dry for no less than 24 hours.
- vi. Apply standard Softroc 6 – 12 mm EPDM topcoat to colour specified.
- vii. Softroc water play systems should be left for 5 days before general use.

2.3 TESTING: The system should be tested to the following standard.

- A. Hardness: ASTM D-2444 94% recovery
- B. Water Absorption: ASTM D-530 +6.5%
- C. Ultraviolet Resistance: ASTM D-3137
- D. Fungal Resistance: Trace to no growth: ASTM G-21
- E. Spread of Flame Resistance: ANSI/UL 790 (ULC-S107) Class A
- F. Accelerated: weathering no change after 2000 hours
- G. Freeze /Thaw: no change after 30 days at minus 50 in 24-hour period

Bounces like rubber. Wears like rock.®

[www.rubaroc.com](http://www.rubaroc.com) | 1-877-782-2762 | [info@rubaroc.com](mailto:info@rubaroc.com)



## PART III - EXECUTION

### 3.1 PREPARATION:

- A. All sub surfaces will be inspected prior to application and any discrepancies will be reported to the owner or his agent. Installation will not proceed until any problems are rectified. Unless specified the owner is responsible for the subbase (substrate).
- B. Clean the substrate with broom or shop-vac as required. Use of a pressure washer may be required if substrate is extremely dirty (Sufficient time must be allowed for the surface to thoroughly dry).
- C. Install retaining edging or forms if required.

### 3.2 MIXING / APPLICATION – Pool deck / Splash pad Surface

- A. Using a short nap roller, roll onto substrate surfaces one coat of primer at approximately 50 square feet per liter. Primer is not necessary if covering compacted stone (two-tier system only).
- B. The selected EPDM topcoat granules should be coated with aromatic or aliphatic resin in a non-porous container at a resin to granule ratio of 80% rubber to 20%urethane resin by weight. Topcoat should not be less than 6mm and not more than 12mm in depth. It is recommended that the mixing of the topcoat be carried out with an electric vertical shaft mortar mixer to ensure consistency and assuring complete coverage of each granule.
- C. The resin should be applied to the rubber, once the rubber is initially working within the mixer. The above must be mixed for approximately 1-3 minutes.

### 3.3 HEALTH & SAFETY:

- A. When using either resin or solvent products, whether during mixing or application, the wearing of protective gloves is essential. This will protect contact of the skin directly with the above materials. The gloves will be required to be changed regularly throughout the installation and sufficient quantities of same should be allowed for.
- B. Should any resin or solvent come into contact with the skin, this must be immediately washed off using suitable detergents and water.
- C. When troweling the product, it is recommended that rubber kneepads with Velcro straps or knee boards be used.
- D. Read all Material Safety Data Sheets (MSDS) prior to installation. All relevant MSDS should be on site during installation.

### 3.4 SITE PROTECTION:

Bounces like rubber. Wears like rock.®

[www.rubaroc.com](http://www.rubaroc.com) | 1-877-782-2762 | [info@rubaroc.com](mailto:info@rubaroc.com)



A. Erect barricades or caution tape as required to prevent inadvertent pedestrian traffic on the finished floor surface for a period of 24-48 hours.

B. On large projects where access to the public is possible, barricades and signs must be implemented around the working area, again to avoid any inadvertent traffic. This is more relevant on projects taking more than one day to complete.

3.5 CLEAN UP: Upon completion of work in the section, remove all tools, equipment, unused materials, and debris from the site; broom clean immediate area.

Please Note:

After the completion of the surface, the EPDM granules may appear to take on a yellowish colour which we refer to as "ambering". This is a result of using an MDI urethane which gives long-term flexibility to the surface, but also a short-term ambered colour. This will "burn off" with normal activity and sunlight in a short period of time.

An Aliphatic (UV Resin) resin is also available at an increased cost; however, it will not cause an "Ambering" effect on the surface.

Various typical details can be seen below:

### 3/8" CAP OVER CONCRETE FOR SIDEWALKS & POOL DECKS

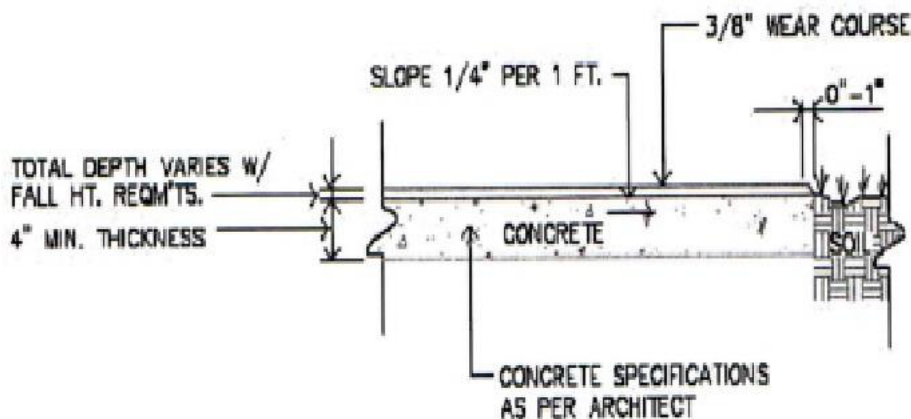

Notes:

Transition zone varies with depth changes.

Transition zone will have no greater than 1" fall per 20" horizontal slope.

### KEYCUT OVER NEW OR EXISTING BASE

Bounces like rubber. Wears like rock.®

www.rubaroc.com | 1-877-782-2762 | info@rubaroc.com

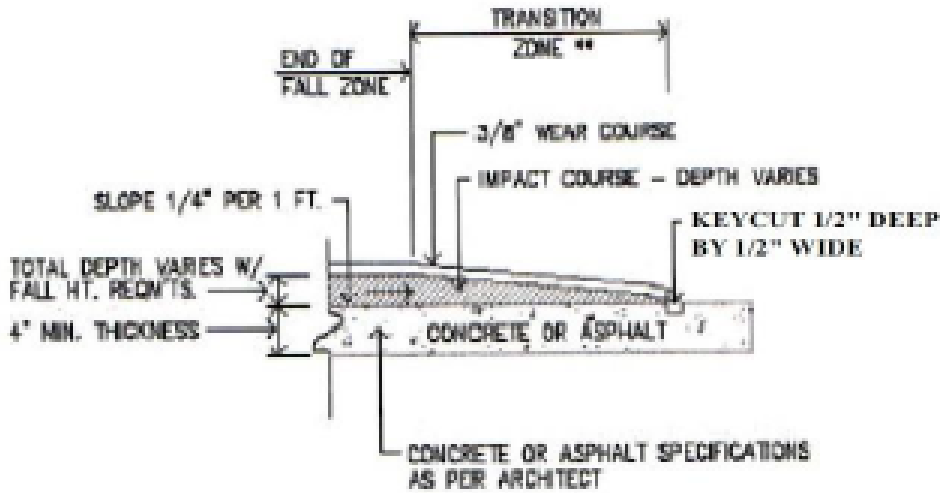

Notes:

Transition zone varies with depth changes.

Transition zone will have no greater than 1" fall per 20" horizontal slope.

Water applications excluded for asphalt base.

#### TYPICAL DRAIN DETAIL

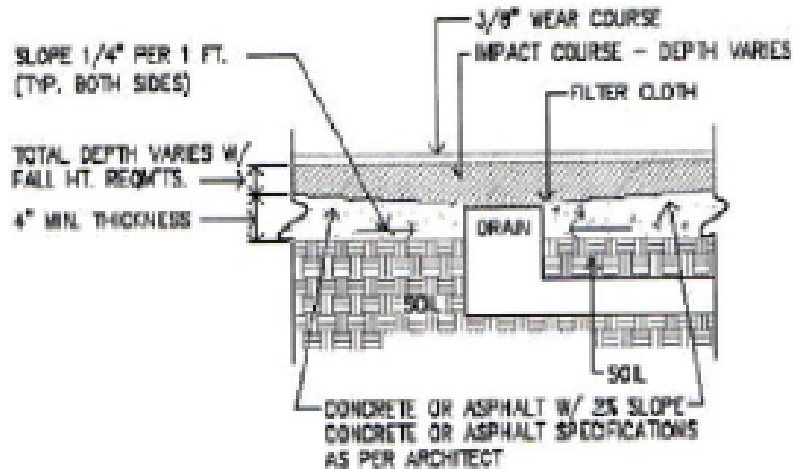

Notes:

Drain should be flush with concrete.

Water applications excluded for asphalt base.

#### CONCRETE BASE ADJACENT TO GRASS EDGE

Bounces like rubber. Wears like rock.®

www.rubaroc.com | 1-877-782-2762 | info@rubaroc.com

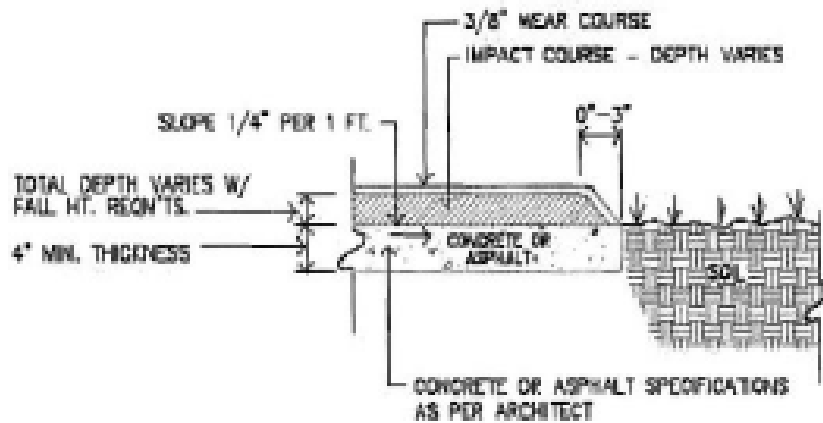

Notes:  
Transition zone varies with depth changes.  
Water applications excluded for asphalt base.

#### RECESSED BASE ADJACENT TO CONCRETE EDGE

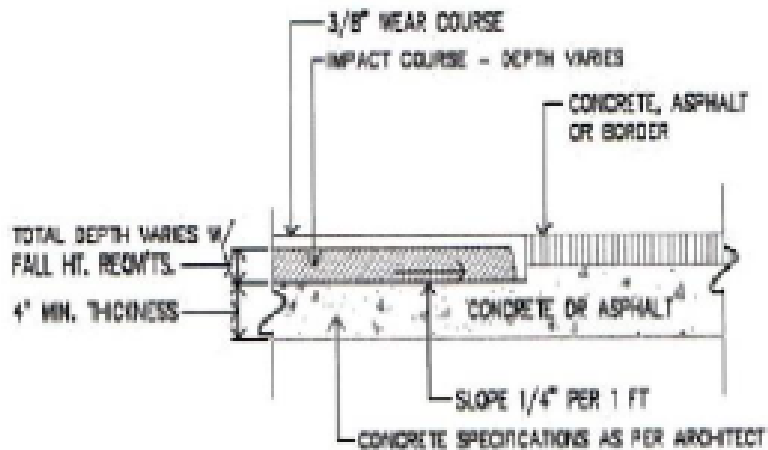

Bounces like rubber. Wears like rock.®

[www.rubaroc.com](http://www.rubaroc.com) | 1-877-782-2762 | [info@rubaroc.com](mailto:info@rubaroc.com)



## CONCRETE BASE ADJACENT TO CONCRETE SIDEWALK

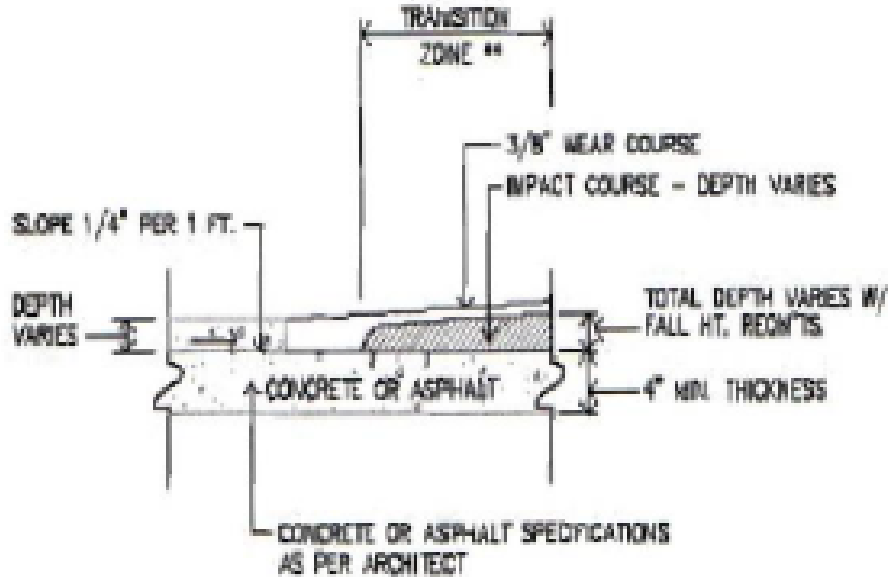

### Notes:

Transition zone varies with depth changes.

Transition zone will have no greater than 1" fall per 20" horizontal slope.

Water applications excluded.

## WEEPHOLE

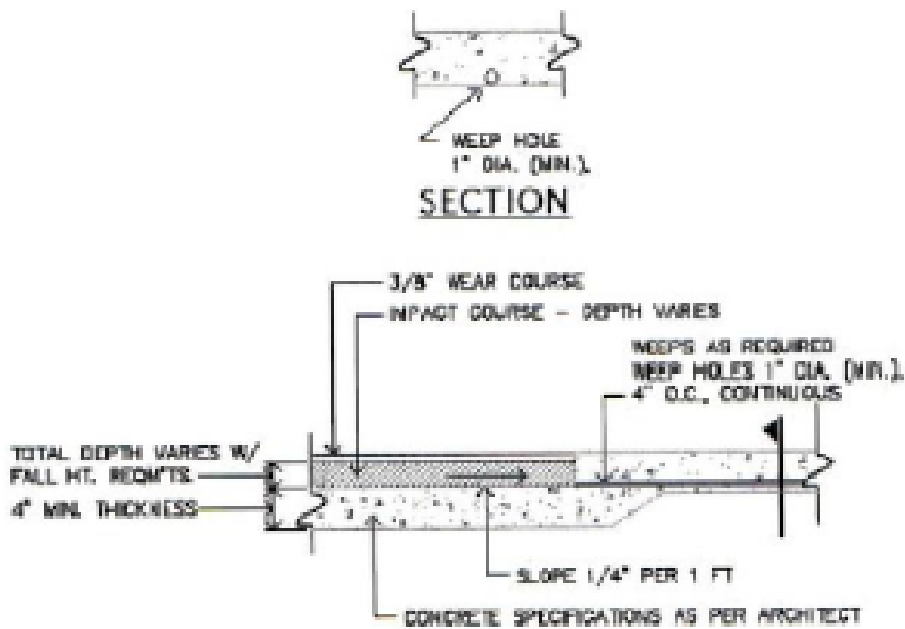

Bounces like rubber. Wears like rock.®

www.rubaroc.com | 1-877-782-2762 | info@rubaroc.com





## FIXED BORDER ADJACENT TO GRASS EDGE

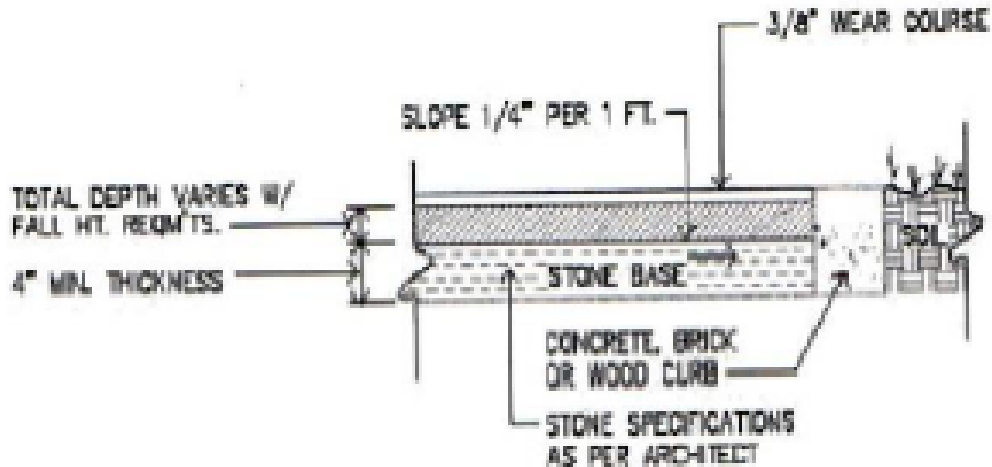

### Notes:

For compacted stone base, filter cloth can be laid on top of stone prior to installation.  
 Industry standard for border is 6" to 8"; 4" to 6" is accepted.  
 Water applications excluded.

## SOFT SHOULDER (SLOPED) EDGE OVER CONCRETE CURB ADJACENT TO LOOSE FILL

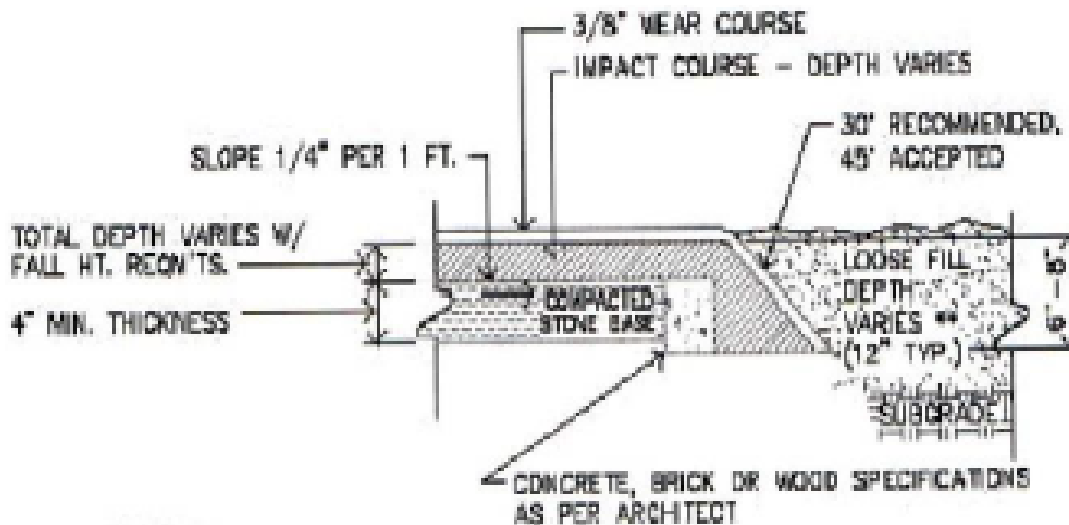

### Notes:

Transition zone varies with depth changes.  
 Loose fill as per manufacturer recommendations, to be installed after Softroc installation.  
 Industry standard for border is 6" to 8"; 4" to 6" is accepted.  
 Water applications excluded.

**Bounces like rubber. Wears like rock.®**

www.rubaroc.com | 1-877-782-2762 | info@rubaroc.com



SOFT SHOULDER (SLOPED) EDGE OVER CONCRETE BASE ADJACENT TO LOOSE FILL

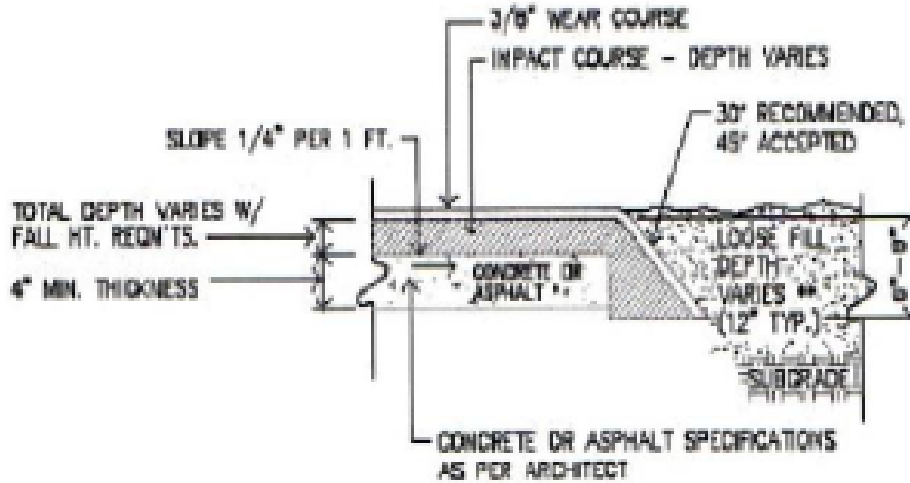

Notes:

Transition zone varies with depth changes.

Loose fill as per manufacturer recommendations, to be installed after Softroc installation.

Water applications excluded for asphalt base.

SHOFT SHOULDER/CURB ADJACENT TO LOOSE FILL

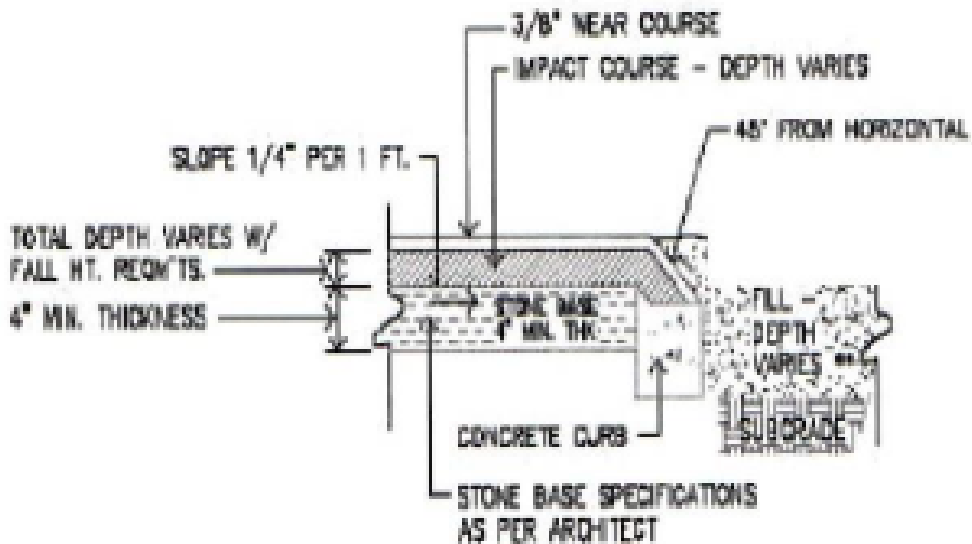

Notes:

Transition zone varies with depth changes.

Loose fill as per manufacturer recommendations, to be installed after Softroc installation.

Water applications excluded.

SOFT SHOULDER (SLOPED) EDGE OVER CONCRETE BASE ADJACENT TO LOOSE FILL

Bounces like rubber. Wears like rock.®

www.rubaroc.com | 1-877-782-2762 | info@rubaroc.com

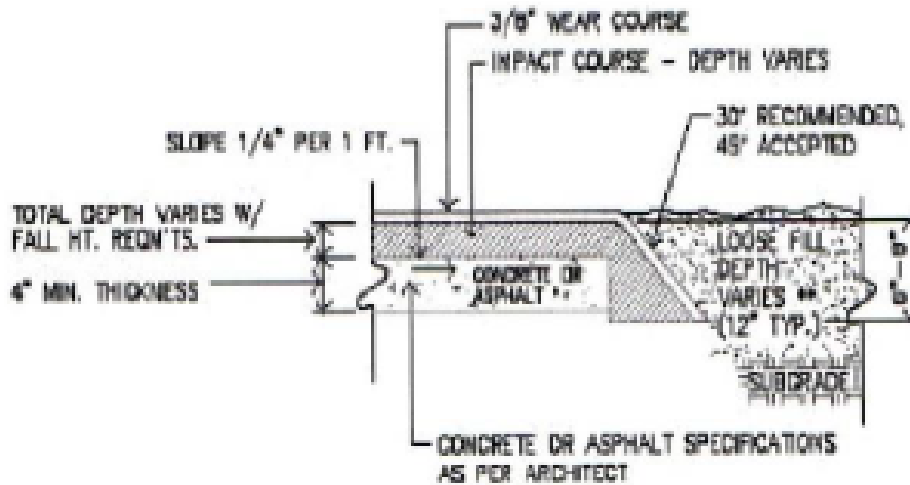

Notes:

Transition zone varies with depth changes.

Loose fill as per manufacturer recommendations, to be installed after Softroc installation.

Water applications excluded for asphalt base.

SLOPED CONCRETE ADJACENT TO LOOSE FILL

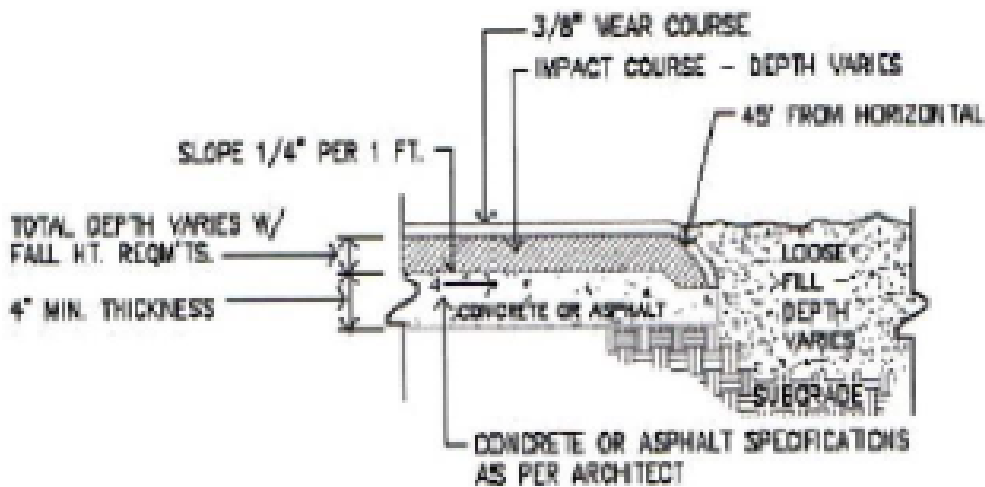

Notes:

Transition zone varies with depth changes.

Loose fill as per manufacturer recommendations, to be installed after Softroc installation.

Water applications excluded for asphalt base.

SOFTROC SAFETY SURFACE DEPTH FALL ZONE TRANSITION

Bounces like rubber. Wears like rock.®

www.rubaroc.com | 1-877-782-2762 | info@rubaroc.com

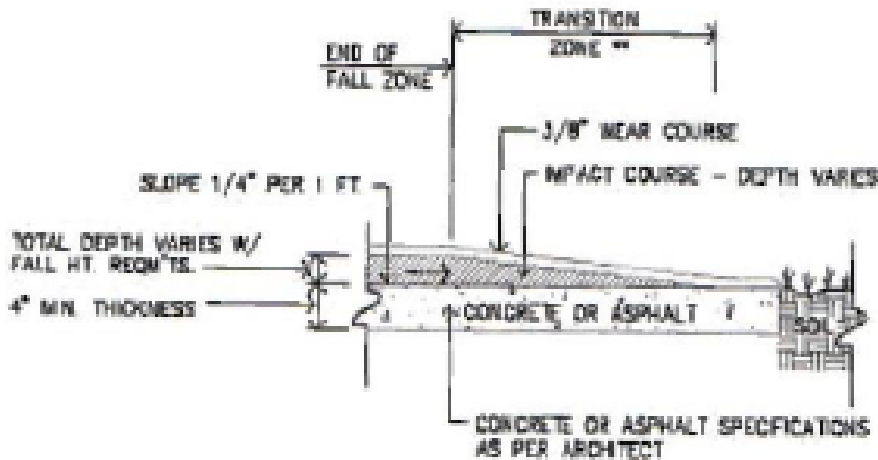

Notes:

Transition zone varies with depth changes.

Transition zone will have no greater than 1" fall per 20" horizontal slope.

#### SOFTROC SAFETY SURFACE AROUND EQUIPMENT COLUMN

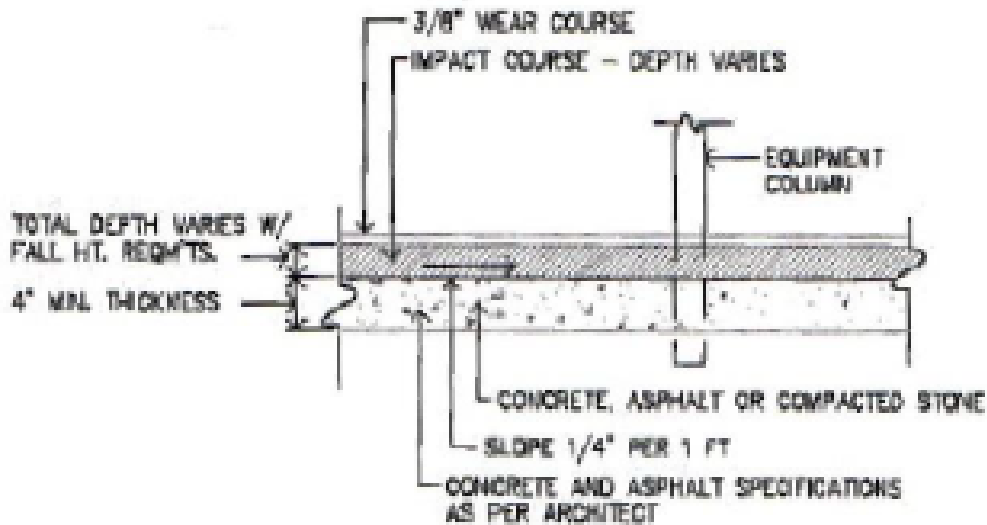

Notes:

Of compacted stone base, filter cloth can be laid on top of stone prior to installation of Softroc.

Water applications excluded for asphalt base.

Bounces like rubber. Wears like rock.®

www.rubaroc.com | 1-877-782-2762 | info@rubaroc.com